

# Statistical experimental design techniques to investigate the strength of adhesively bonded T-joints

L.S. Sutherland, C. Amado, C. Guedes Soares

## Abstract

Statistical experimental design techniques were used to study the strength of 'T'-Joints representative of various connections used to fabricate marine composite structures via a large test program. The effects of different surface preparations and cleaning methods, and adhesives were investigated. An analysis of variance was conducted, giving an extremely good fit to the experimental data. Importantly, the statistical methods identified significant interaction effects; the effect of each parameter varied considerably between the different levels of the other parameters. Interaction plots were found to be indispensable both in clearly presenting and understanding the complex relationships seen in the data, and in interpreting the results in terms of a number of practical engineering conclusions.

## Keywords

Marine, Bonding, Mechanical testing, Experimental design, Analysis of variance (ANOVA)

## 1. Introduction

Composites offer many advantages over construction materials traditionally used in the marine industry such as steel or aluminium. These include resistance to the marine environment, ease of producing seamless multiple-curvature parts, and high specific strength. Hence, composites in the form of glass fibre reinforced polyester has for many years been ubiquitously used in the leisure craft and work boat industries [1].

However, fabrication of the hull is by no means the end of production; the bare hull must be turned into the finished vessel through the addition of stiffeners, decks, superstructure, bulkheads and fittings, all of which must be joined together. This may require up to 50% of the total time and cost of build [2]. Welding is obviously not an option for joining GRP, and mechanically fastening often induces stress concentrations.

Bonding is cheaper, lighter, needs significantly less assembly time, can join dissimilar materials and GRP, does not change the base material properties, allows the use of thinner plating, can be performed from one side of the panel, and spreads the load over a greater area [1–4]. Flexible adhesives can also reduce vibrations, compensate for tolerance problems in large component assembly, accommodate thermal expansion differences and reduce stresses due to deformations [2,3,5]. Importantly in a marine context, bonding may also replace over-laminating to fix stiffeners to panels [6,7], significantly reducing the labour and time required. Hence, adhesive bonding is a very attractive option.

However, the joining of these materials is very sensitive to many factors including the adhesives used, substrate preparation and adhesive application methods and conditions [3,5]. Surface preparation is especially critical in the marine industry given the generally less clean environment of a typical shipyard [2,5].

Often, especially in a production context, the effects of each of such parameters are studied 'one-at-a-time', i.e. the effects of each parameter in turn is only studied at the 'nominal'

value of the others. However, this approach is severely lacking because the effects of one parameter may well be different at different values of another parameter. In the terminology of experimental design, this is known as 'interaction' between the effects of the parameters. In fact previous research into the behaviour of marine composite materials [8–10] has shown that interaction between parameter effects is the norm rather than the exception.

This type of problem is where statistically designed experimental techniques [8,11,12] become extremely useful, if not essential, to investigate such phenomena and then to analyse and, importantly, present the results in a clear and interpretable manner. These methods provide a systematic approach to the planning and execution of the experimentation, and subsequent presentation, analysis and interpretation of the results obtained. Most importantly they are able to investigate, and clearly represent, any 'interactions' between parameters that occur.

It is important to note that although these statistical experimental design techniques have been used here to investigate the multi-parameter problem of the bonding of composite materials, they may be applied to any problem involving multiple factors, each of whose effects may well be dependent on the values taken by the other factors, and that many aspects of the behaviour of composite materials fall within this category.

A commonly used joint geometry for a large number of bonds found in the construction of a marine going vessel is the 'T'-joint, which is representative of many bonded structures including deck-hull, bulkhead-hull and deck-superstructure joints, amongst others. Hence, an experimental study of the effects of a number of parameters commonly used in marine bonding on the strength of T-joints has been completed and statistical analyses and engineering interpretations of the results carried out, as described in this paper.

## 2. Experimental design

Since this terminology is used henceforth in this paper a number of terms used in the language of designed experiments are defined below [8,13]:

- The design parameters and their values are referred to as 'factors' and 'factor levels' (or simply 'levels') respectively.
- The experimental program, or 'design', is carried out at several pre-designed combinations of these factor levels, each of which is termed a 'run' or 'treatment combination' (or just 'treatment').
- The measured result of the experiment is called the 'response variable' (or just 'response').

The main driving force behind this study was to see if the use of different adhesives at the shipyard 'Estaleiros Navais de Peniche' (ENP) would require different levels of surface preparation. Hence, the main surface preparation methods used at ENP were selected to give the three levels of surface preparation (factor 'PREP') to be considered.

Two methods of surface preparation commonly used in the marine industry are simple mechanical grinding using hand-held angle grinders, and the use of a peel ply where a textured polymer sheet is put on the uncured laminate and peeled off when cured (and preferably just before bonding) leaving a clean and textured substrate surface. Since, if feasible, it would result in considerable cost savings a third level of no surface preparation

was also considered. Hence the levels of the surface preparation factor (PREP) consisted of either no preparation ('None'), manual grinding ('Ground'), or the use of a peel-ply ('Peel') (Table 1).

Factor	Level 1	Level 2	Level 3
Surface Preparation (PREP)	'None'	'Ground'	'Peel'
Surface Cleaning (CLEAN)	'Cloth'	'Solv'	-
Adhesive (ADHES)	'Crest'	'Cryst'	'Poly'

Table 1. Factors & levels.

Additionally, the surface may be either simply cleaned with a clean, dry cloth, or better cleaned and then 'activated' (i.e. by breaking some of the long-string polymer bonds to allow improved secondary bonding) by wiping with acetone and then monostyrene solvents. However, since this was an additional 'surface preparation' that could be used, or not used alongside any of the three 'PREP' levels, this was selected as an additional 'surface cleaning' factor ('CLEAN') with two levels; 'Cloth' and 'Solv' referring to wiping with a dry cloth and solvents, respectively (Table 1).

Finally, three candidate adhesives were selected for the levels of the adhesive ('ADHES') factor, again considering production methods at ENP (Table 1):

- i. **'Crest'**: Scott Bader Crestomer 1186PA
- ii. **'Cryst'**: Scott Bader Crystic 2655PA (now '90-82PA')
- iii. **'Poly'**: A polyester putty of 25% mass content microfibers in Scott Bader orthophthalic 446 PALV resin.

The next step was to decide which combinations of each factor levels were to be used to fabricate T-joint specimens for testing. Clearly there are 18 possible permutations of the levels of the three factors (i.e. treatment combinations or experimental runs), but often statistical experimental design techniques are used in order to reduce the amount of experimental resources and effort required via carrying out only a carefully selected subset of all of the experimental runs possible.

However, this requires that some or all higher level interactions are small enough to allow variations measured due to these interactions to be wholly attributed to and used as an estimate of the experimental error for use in the statistical testing that forms an integral part of the technique. Previous experience [8–10] led to the assumption that level interactions likely to be significant (as proved to be the case, see Section 6), and it was decided to test T-joints with every possible permutation of the various factor levels.

Further, the same experience has shown that variability of such hand-produced marine type laminates is relatively high and that replications of each specimen is advisable, if not obligatory. Hence, three replications of each T-joint specimen, (i.e. each treatment) were tested to give a total of 54 experimental runs (Table 2).

Run N <sup>o</sup> s	PREP	CLEAN	ADHES	Mean Fail (N)	Fail Mode
1 - 3	None	Cloth	Crest	716	BS
4 - 6	None	Cloth	Cryst	87	UBLWS
7 - 9	None	Cloth	Poly	0	BS
10 - 12	None	Solv	Crest	1284	UBD / BCT
13 - 15	None	Solv	Cryst	279	BS
16 - 18	None	Solv	Poly	212	LBUWS
19 - 21	Grind	Cloth	Crest	931	UBD
22 - 24	Grind	Cloth	Cryst	698	UBD /UWC
25 - 27	Grind	Cloth	Poly	722	UWC
28 - 30	Grind	Solv	Crest	1036	UWC/ BCT / UBD
31 - 33	Grind	Solv	Cryst	1189	UWC / UBD
34 - 36	Grind	Solv	Poly	974	UWC
37 - 39	Peel	Cloth	Crest	742	UBD
40 - 42	Peel	Cloth	Cryst	912	BS
43 - 45	Peel	Cloth	Poly	828	BS
46 - 48	Peel	Solv	Crest	1053	UBD
49 - 51	Peel	Solv	Cryst	773	BS
52 - 54	Peel	Solv	Poly	869	BS

Table 2. Experimental design and results.

### 3. Experimental details

All specimens were fabricated under typical shipyard conditions at Estaleiros Navais de Peniche. Coremat sandwich laminate panels were first hand laid - up with vacuum assistance using E - glass reinforced Scott Bader orthophthalic resin 446 PALV skins and a Lantor Coremat XM4 core. The laminate schedule used was [600CSM,(300CSM,800WR)2,XM4]<sub>s</sub>, where: 300, 600 & 800 are areal weights in gm<sup>-2</sup>, CSM is Chopped Strand Mat, WR is balanced Woven Roving, and XM4 is Coremat.

18 Pairs of long panels of this sandwich laminate were then cut out, and each pair subjected to the appropriate surface treatment and then bonded together perpendicularly using fillets of the appropriate adhesive applied using a radiused spatula. This gave 18 deep T-joints which were then cut into individual T-joint specimens as 'slices' from this extended T - Joint. The nominal dimensions of the T-joints are given in Fig. 1. Throughout this paper the vertical and horizontal sandwich laminates of Fig. 1 are referred to as the 'web' and the 'base' of the T - joint, respectively.

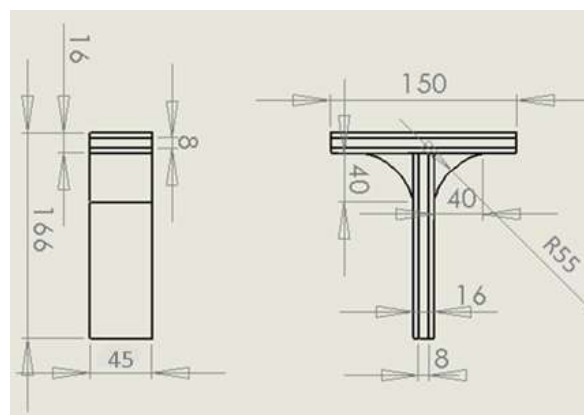

Fig. 1. Nominal T-joint dimensions in mm.

As a suitably severe loading case the joints were supported and loaded as shown in Fig. 2. Actual specimen dimensions were measured and then a calibrated computer-controlled servo-hydraulic test machine was used to load the specimens at a controlled displacement rate of 0.1 mm/s until failure of the joint produced a significant and sudden drop in load. Force and displacement data was recorded and the strength of the joint taken as the maximum load achieved. Failure modes were also noted as each test progressed, and then verified using video recordings of each test.

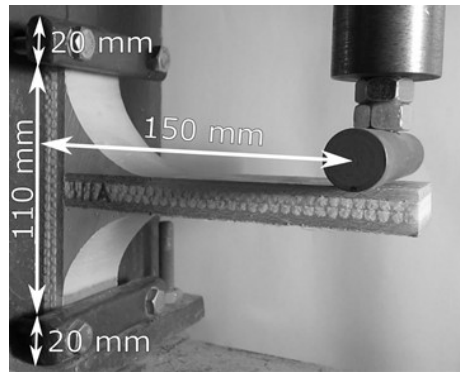

Fig. 2. Test setup.

In order to avoid possible confounding of the data with uncontrollable external factors, the run order was randomised.

#### 4. Results

A typical force-displacement plot and the six initial failure modes seen are shown in Figs. 3 and 4, respectively. In order to ensure that the initial failure modes are clearly visible in Fig. 4, the still photographs were taken from the videos at a time when these initial failure modes were sufficiently developed, meaning that some secondary failure modes are also visible. Since the interest here is the initial failure mode corresponding to loss of load bearing capacity, secondary failure modes were not important and were not studied here.

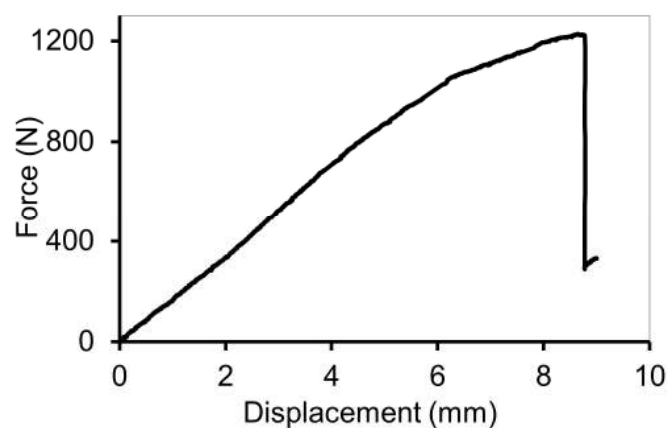

Fig. 3. Typical force-displacement data.

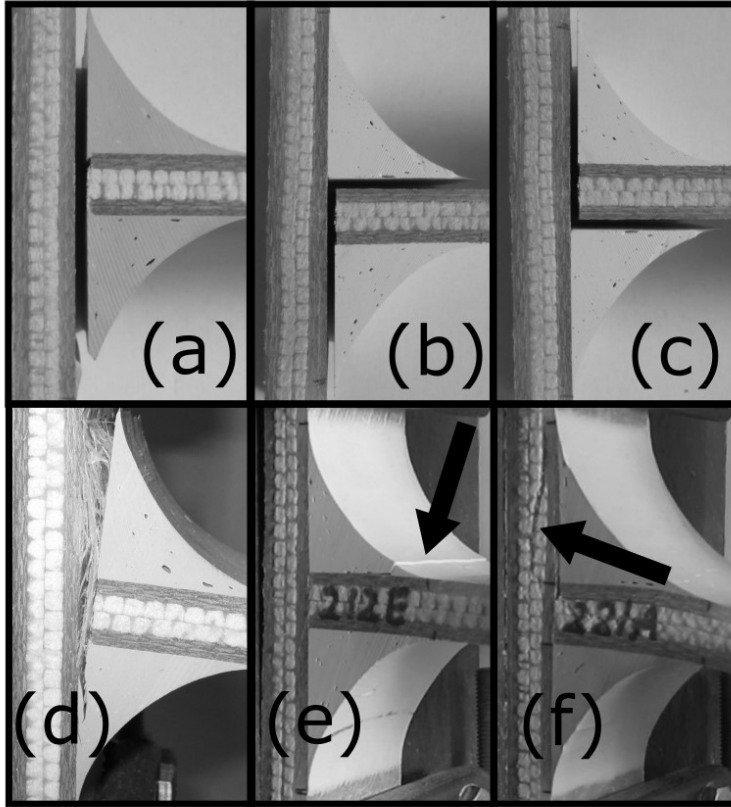

Fig. 4. Failure modes: (a) Base Separation (BS), (b) Lower Base Upper Web Separation (LB/UWS), (c) Upper Base Lower Web Separation (UB/LWS), (d) Upper Base Delamination (UBD), (e) Upper Web Crack (UWC), (f) Base Core Tensile (BCT).

The UWC (Upper Web Crack) mode occurred as the specimen failed (i.e. at the sharp drop in load) and was followed by delamination of the upper web. Similarly, the BCT (Base Core Tensile) failure occurred as the specimen failed (i.e. at the sharp drop in load) and was followed by UBD (Upper Base Delamination) damage.

The measured failure loads  $F_{fail}$  were normalised to account for differences in the measured specimen widths  $b$  from the nominal 45 mm to give the response variable  $MaxF$ :

$$MaxF = \frac{b}{45} F_{fail} \quad (1)$$

The average normalised failure loads of the three repeat tests at each treatment combination are given in Table 2. Those specimens which were so weak to break upon cutting or handling were attributed a failure load of 0 N.

Failure modes as per the abbreviations of Fig. 4 are also given in Table 2, and where all three tests did not give the same failure mode this is indicated.

## 5. Statistical Analyses

The open source, free statistical analysis software 'R' [14] via the 'R-Studio' software [15] was used for the statistical analyses of the experimental data. Appropriate

factor levels were assigned to the factor variables 'PREP', 'CLEAN' and 'ADHES', and normalised experimental data assigned to the response variable 'MaxF'.

An estimated linear model of the maximum force response as described by the three factors and their interaction terms was fitted to the data. A residual analysis to check the validity of the model was performed and a summary of the model generated. An analysis of variance (ANOVA) was then made.

The statistical model was shown to be extremely valid, with an ' $R^2$ ' value of 0.98 (a value of 1.0 indicates a perfect fit to the data) and Levene's tests [16] and a normal Q-Q plot (Fig. 5) of the residuals showed that the data was both homoscedastic (i.e. of homogeneous variance, see Fig. 6) and sufficiently normally distributed for the statistical analyses used here to be considered valid.

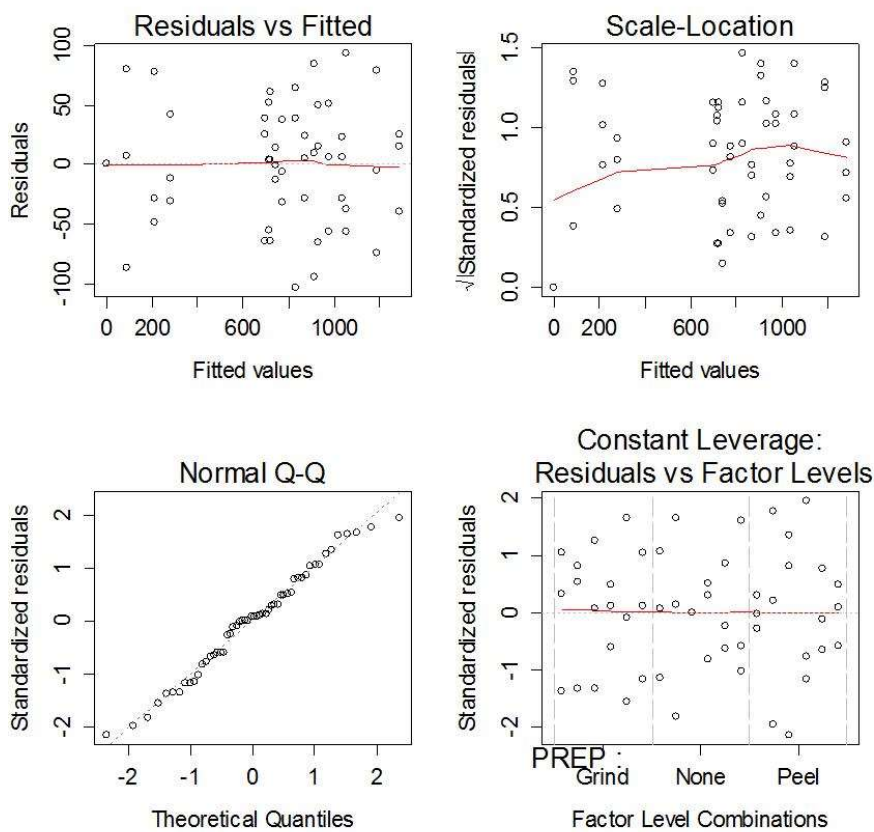

Fig. 5. Residuals Analyses Plots.

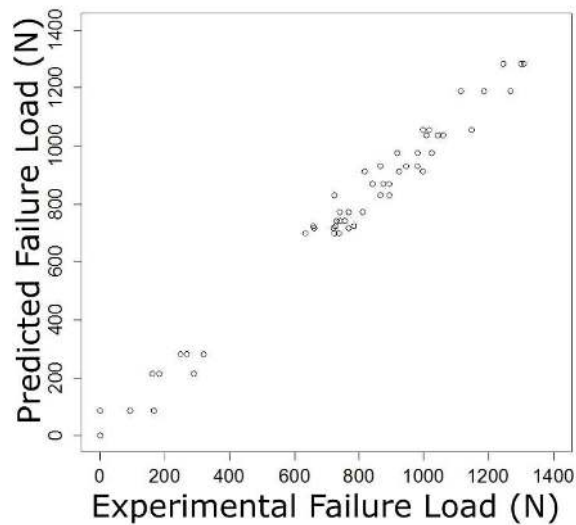

Fig. 6. Experimental – statistical model prediction values (homoscedastic data).

The ANOVA results in Table 3 show that the effects of all three individual factors (the ‘main’ effects) were extremely statistically significant; the last column, the ‘p-value’, is the chance that the effect seen is in fact not real but just due to statistical variation. Since all of the ‘p-values’ in Table 3 are extremely small it is extremely safe to assume that they indicate ‘real effects’.

Response: MaxF	Df	Sum Sq	Mean Sq	F value	Pr(>F)
PREP	2	2619757	1309878	378.8	< 2.2E-16
CLEAN	1	688848	688848	199.2	3.04E-16
ADHES	2	1347755	673878	194.9	< 2.2E-16
PREP:CLEAN	2	166075	83038	24.0	2.37E-07
PREP:ADHES	4	1667367	416842	120.5	< 2.2E-16
CLEAN:ADHES	2	71041	35521	10.3	0.0002956
PREP:CLEAN:ADHES	4	330801	82700	23.9	1.03E-09
Residuals	36	124497	3458		

Table 3. ANOVA table.

It is worth noting here that just because an effect is statistically significant, or ‘real’, it does not have to mean that it is large enough in practical engineering terms to be of any interest; it is just large enough to be distinguished above the statistical ‘noise’ in the data.

Table 3 also shows that all three of the 2-way interaction effects (PREP:CLEAN, PREP:ADHES and CLEAN:ADHES) are also highly statistically significant. This means that not only are the effects of the three factors significant, but their effects also vary significantly between the different levels of the other factors. Further, Table 3 shows that the 3-way interaction effect (PREP:CLEAN:ADHES) is also highly statistically significant. This means that not only does the effect of one factor vary significantly between the different levels of another factors to give an interaction effect, but that the form and/or degree of this interaction itself depends upon the level of the third level.

An ‘interaction plot’ facilitates the interpretation of factor main and 2-way interaction effects. In order to illustrate this and further clarify the previous two paragraphs, such a plot



for the data here is shown in Fig. 7. However, as will be explained below, *it is extremely important to realise that this figure may not be used to draw any conclusions about the data* since the significance of the 3-way interaction effect seen here means that this plot has no meaningful interpretation; it is included here only as for illustrative purposes.

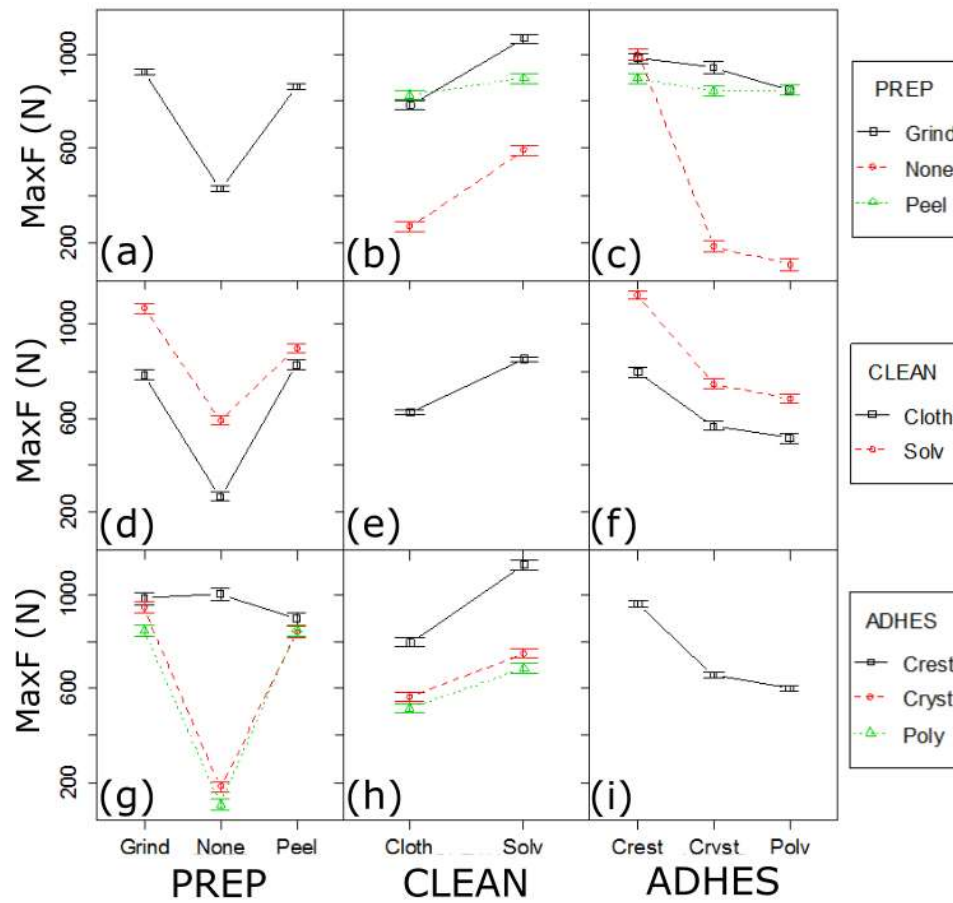

Fig. 7. 2-Way interaction plot (NB: Only for illustrative purposes).

Fig. 7 (a), (e) and (i) present the three main factor effects, PREP, CLEAN & ADHES, respectively. Fig. 7 (b) and (d) present the same 2-way interaction effect, PREP:CLEAN, in two different ways, namely the change of the effect of CLEAN at the three different levels of PREP, and the change of the effect of PREP at the two different levels of CLEAN, respectively. Although the plots have different appearances they are in fact equivalent, as can be seen through closer inspection which shows that the same 6 data points are plotted in both graphs. Similarly, Fig. 7 (c) and (g), and Fig. 7 (f) and (h) present the 2-way interaction effects PREP:ADHES and CLEAN:ADHES.

The main factor effects are themselves averages of the responses measured at different levels of the other factors, for example Fig. 7 (a) may be obtained by averaging the points from each of the lines in the 2-way interaction plot Fig. 7 (d), or alternatively in Fig. 7 (g). Clearly, if the lines in the interaction plot are parallel to each other then this averaging process makes sense because the effect of the main factor at each level of the second factor is the same. However, taking Fig. 7 (g) as an example, the effect of PREP is seen to be different at the Crest level of ADHES, and so averaging the effect of PREP over the three levels of ADHES gives meaningless results.

This is an important point to realise; that if there is a significant interaction effect then the main factor effects themselves are meaningless and interaction effects must be presented. This must also be extended to significant three-way interaction effects, as is the case here. A ‘three-way’ interaction simply means that the two-way interaction effects themselves are not the same at all levels of a third factor. In the same way in which the main factor effect plots are average plots of the separate lines of the relevant 2-way interaction plots, the two-way interaction plots of Fig. 7 are themselves average plots of separate lines at the different levels of the third factor. Fig. 8 presents the significant three way interaction effect in terms of the variation in the interaction effect between PREP and ADHES with between the two levels of the third factor, CLEAN. As for discussed previously for the two way interactions, the two plots of Fig. 8 are simply different interpretations of the same 3-way effect; the same 18 points are plotted in both graphs. Each of these points is itself the average value of the three replications at each of the 18 combinations of this experimental design.

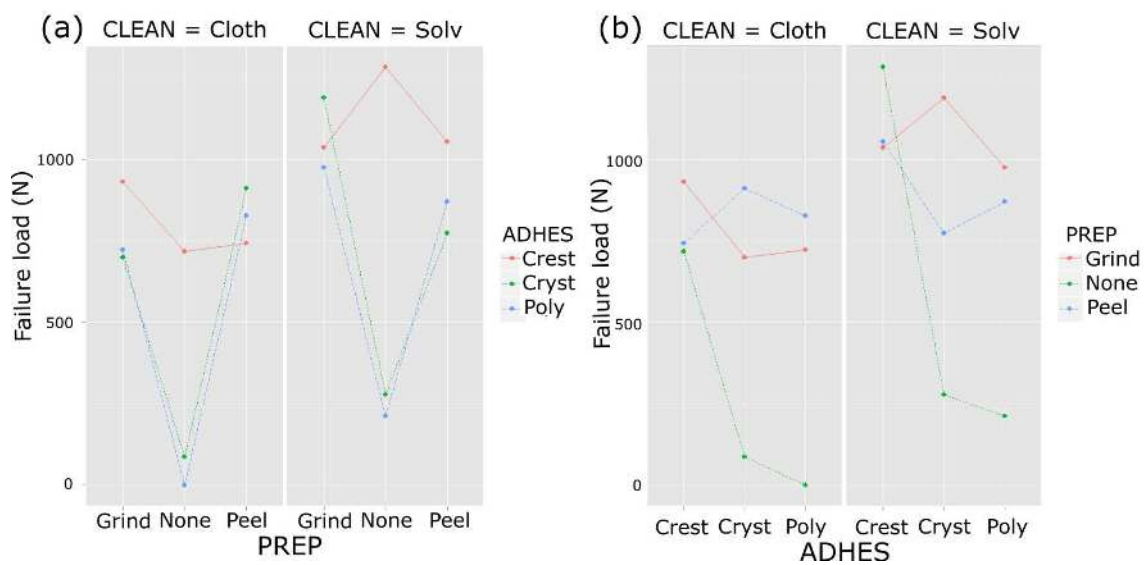

Fig. 8. 3-Way interaction in terms of interaction between PREP and ADHES.

Now it becomes apparent that the two-way interaction effect PREP:ADHES of Fig. 7 (g) is itself plotted using the values averaged between the two plots of Fig. 8 (a), and that since these two plots of Fig. 8 (a) are not equivalent, this averaging process is not meaningful since it obscures the difference in the two-way PREP:ADHES interaction effect between the two levels of the third factor, CLEAN.

Further, there are also four equivalent additional interpretations of the single three-way interaction effect seen here, which are presented in Fig. 9. Again closer inspection shows that the same 18 points are plotted in all six plots of Figs. 8 and 9, and that they are all just different interpretations of the same three-way interaction effect PREP:CLEAN:ADHES. The choice of which plot to use to make engineering interpretations of the data is hence one of choice, made to provide, for example, the clearest or the most standard interpretation.

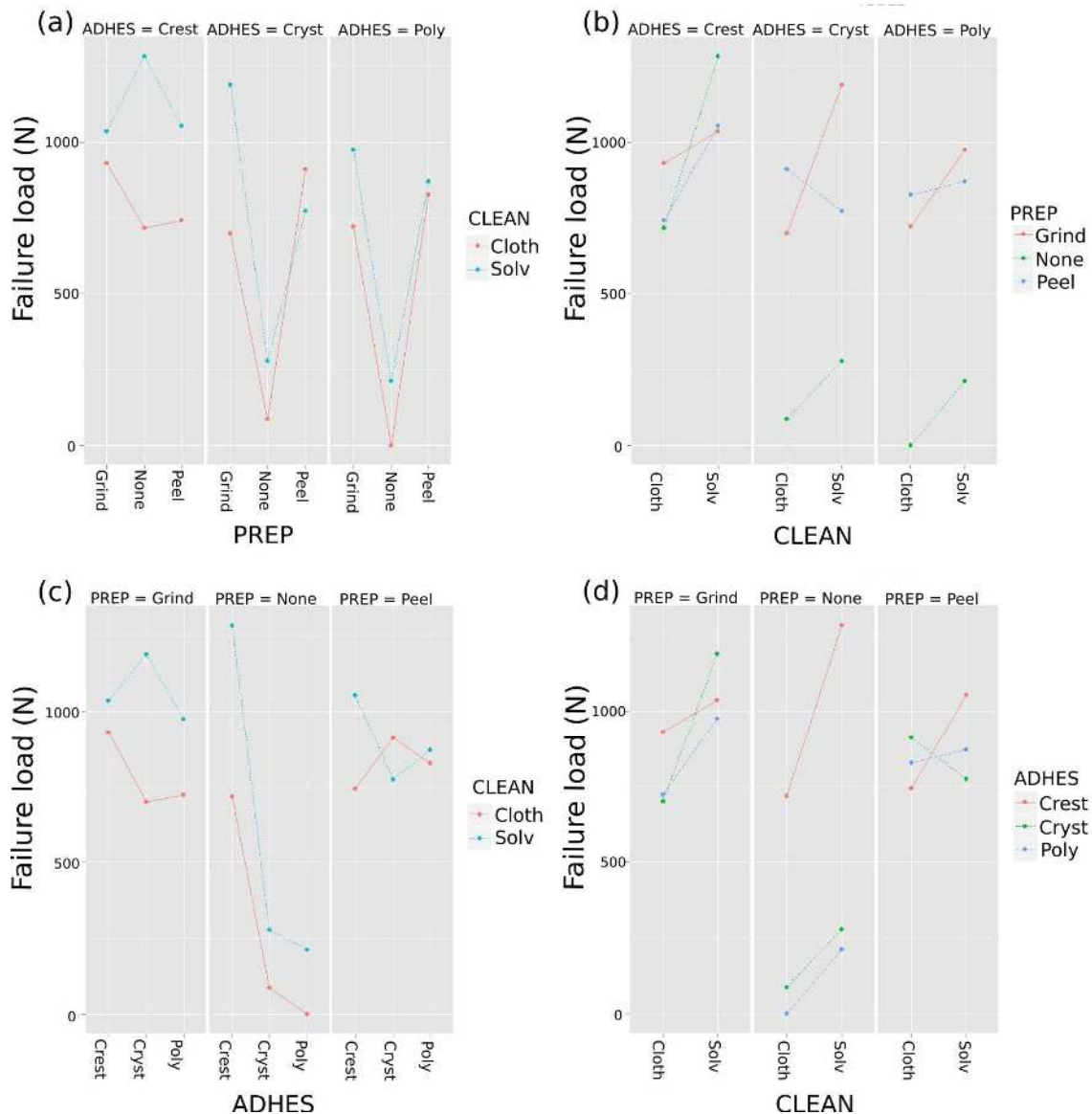

Fig. 9. 3-Way interaction in terms of interactions between PREP and CLEAN, and ADHES and CLEAN.

The consequence of this is that if there is an 'X'-way interaction then all interactions at levels below 'X' have no meaningful interpretation. In this case there is a very significant three-way interaction between PREP, CLEAN and ADHES and so it must be reiterated that both the 2-way interaction, and the main factor effect plots, of Fig. 7 *must not* be used to interpret the behaviour seen, but are only included here to facilitate the explanations made in the previous paragraphs. All interpretations must be made using any of the equivalent plots of Fig. 8 and Fig. 9.

Previous work [17] considered only the subset of the data for which there was no surface preparation, i.e. for which PREP = 'None'. In this previous study the two way interactions presented are meaningful since they are not averaged over the three levels of the PREP factor. However, it is important to remember that the results from this data subset only correspond to specimens with no surface preparation, and that different trends could, and in this case were, seen for other surface preparations. This illustrates well why the

traditional 'one-(parameter)-at-a-time' experimental approach (where separate test programs vary only a single parameter and the data is analysed separately) is not an effective approach, and is prone to give conflicting results between different studies if all the many test and material parameters are not kept identical.

This ability of statistically designed experimentation and analysis to systematically investigate, and, importantly, to clearly represent graphically, factor interactions is a very powerful tool, extremely useful (if not essential) in any situation where multiple parameters affect the measured response and interactions between the factor effects are possible. Many areas of research into composite materials fall into this multi-parametric category, as seen, for example in [8–10].

## 6. Discussion

### 6.1. Engineering interpretation of statistical results

This is the most important and useful part of the experimental design process. It is worth repeating that a statistically significant effect does not necessarily infer an important effect in practical terms; it may still be too small to be of any practical importance.

The interpretations made below are based on Fig. 9(b) and (d) since the authors consider these to be both the most relevant in terms of common practice and those giving the clearest interpretation. However, the reader is free to use any of the plots in Figs. 8 and 9 to make equivalent interpretations, of which there are numerous possibilities. Of course, since all of the 6 pots of Figs. 8 and 9 use the same 18 points, any alternative interpretations can only be differently worded versions of those discussed here.

The simplest question to ask of the results is 'which treatment combination gives the strongest T-joint?' Any of the plots of Figs. 8 and 9 show this to be one cleaned with solvents, bonded with Crestomer and, perhaps surprisingly, with no surface preparation (None/Solv/Crest) with an average (over the three replications tested at this treatment) maximum load of 1285 N. However, treatment Grind/Solv/Cryst gives an average maximum load of 1187 N, and it is not clear that this value is significantly lower than the None/Solv/Crest given the inherent experimental variation.

In order to evaluate this quantitatively a statistical two sample Student's *t*-test is used to estimate the probability that the means of the two sets of three replication results are the same (i.e. the true difference between the means is equal to zero). Since the *t*-test returns a *p*-value of 0.120 it is difficult to conclusively assume that the Grind/Solv/Cryst joint is in fact the strongest (i.e. there is a significant difference in means). However, ultimately it is up to the designer to decide if an increase in strength of this magnitude is in fact *important* in a practical sense.

Both Fig. 9 (b) and (d) very clearly identify the treatment combinations responsible for the two distinct groups of data seen in Fig. 6; the weaker group is made up of the Crystic and polyester putty bonded joints with no surface preparation.

It is also essential to remember that there are other practical production and cost considerations to be taken into account which may mean that the strongest joint is not necessarily the optimum one. Hence, further comparisons are made below consulting Fig.

9 and making further use of the two sample Student's *t*-test between the relevant pair of treatment combination results sets (of three replications) in each case.

Fig. 9 (b) gives an interpretation of the data which is useful if comparisons between the behaviours of the three adhesives considered here is required:

- a) If the Crestomer adhesive is used then the joint should be cleaned before bonding using solvents. Any surface preparation is seen to give a strong joint, with grinding and peel-ply giving the same strength (*t*-test *p*-value = 0.749) of approximately 1030 N, and no preparation giving a significantly higher (*t*-test *p*-value = 0.011) failure load of 1285 N.
- b) If the Crystic adhesive is used the surface *must* be prepared either by grinding or using peel-ply. Grinding followed by solvents gives a significantly higher strength (1187 N) than that using peel ply with simple cleaning (912 N, *t*-test *p*-value = 0.016). Interestingly, there is some evidence for a statistically significant lowering of strength when using peel-ply with solvents compared to using a simple cloth (716 N c.f. 912 N, *t*-test *p*-value = 0.065).
- c) If a Polyester putty is used for bonding, the surface *must* be prepared either by grinding or using peel-ply. The strongest such joint is observed to be a ground one cleaned with solvents (971 N), confirmed by the *t*-test *p*-value of 0.039 when compared with Peel/Solv/Poly (873 N). For grinding, cleaning with solvents is seen to increase the strength over simple cleaning with a cloth, but for peel-ply there is little evidence for solvents to give stronger joints (*t*-test *p*-value of 0.488).

As an alternative interpretation of the results, Fig. 9 (d) is useful if making comparison between surface preparations:

- (i) If avoiding labour intensive surface preparation is attractive, then Fig. 9 (d) clearly shows that neither Crystic nor polyester putty should be used as the adhesive. As discussed above, a solvent-cleaned Crestomer-bonded joint should be used, which is actually the strongest of all the types of joint in this study (1285 N). These conclusions are also clearly evident from the centre plot of Fig. 9 (c).
- (ii) If the surface is prepared by grinding, then all three adhesives give a strong bond, with solvents giving the most effective cleaning in each case. The Crestomer bonded solvent cleaned joints were the strongest (1030 N, *t*-test *p*-value of 0.031 compared with the equivalent Crystic joints), but there was not strong evidence that these Crystic bonded joints were significantly stronger than the polyester putty bonded ones (971 N, *t*-test *p*-value = 0.148).
- (iii) If peel ply is used then again all three adhesives give a strong bond, but the effect of cleaning before bonding with solvents is not so straightforward. Again, Crestomer bonded, solvent cleaned joints are the strongest peel ply prepared joint (1049 N, *t*-test *p*-value of 0.021 compared with the equivalent polyester putty bonded joints, 873 N) and are stronger than the equivalent Crestomer cloth cleaned joints. However, there is no significant effect of cleaning method for the polyester bonded joints (*t*-test *p*-value = 0.488), and for the Crystic

bonded joints there is some evidence statistically ( $t$ -joint  $p$ -value = 0.065) that the use of a solvent actually reduced the strength of the joints.

- (iv) Hence, overall the two best candidates for a strong joint are Crestomer with no surface preparation (1285 N) and Crystic with grinding (1187 N), both pre-cleaned with solvents. However, the combinations Peel/Solv/Crest, Grind/Solv/Crest and Grind/Solv/Poly (1049 N, 1030 N and 971 N, respectively) also give more than respectable joint strength, and since there is little to choose between them (lowest two sample  $t$ -test  $p$ -value of 0.235) the cheap cost and simplicity of the latter of the three could be advantageous.

As stated above, these conclusions, and slightly different interpretations of them, may be seen in any of the plots of Figs. 8 and 9, and  $t$ -tests may be used to see if the differences between any pair of the 18 treatment combinations are statistically relevant (then it is up to the engineer to decide if any statistical difference is actually practically important, or worthwhile). However, because there is a large number of both these different interpretations and of comparisons between data pairs, and because the important ones have been described above, this is not done here in order to keep the discussion reasonably succinct.

It can be seen that the statistical experimental design methods used have enabled a very concise and clear presentation of a complex set of interactions between the effects of the three factors considered here. These interactions would not even have been discovered if the effects of each factor was investigated at only one level of the other factors, easily leading to incomplete or even false conclusions.

However, it is important to remember that all conclusions made here are for the specific test setup considered here, and that a study of this size cannot address all relevant bonding effects such as ageing, fatigue etc.

## 6.2. Failure modes

The failure modes seen may be categorised into two groups:

1. Interface failures/Separation
  - Base, Fig. 4 (a)
  - Lower Base/Upper Web, Fig. 4 (b)
  - Upper Base/Lower Web, Fig. 4 (c)
2. Internal failures
  - Upper Base Delamination, Fig. 4 (d)
  - Upper Web Crack, Fig. 4 (e)
  - Base Core Tensile, Fig. 4 (f)

Fig. 10 shows the data points of Fig. 9 (d) annotated with failure mode(s) (Table 2).

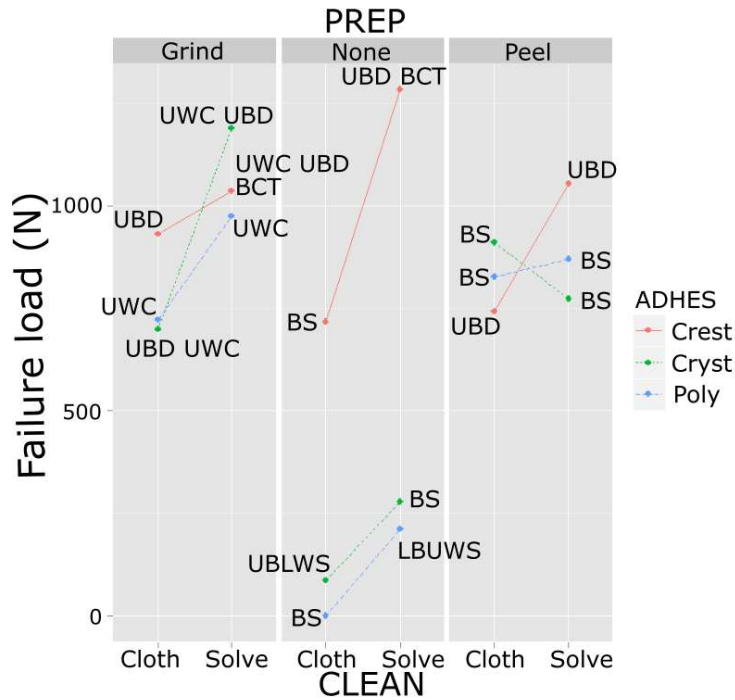

Fig. 10. CLEAN:ADHES Interactions with failure modes.

The main points that may be drawn from Fig. 10 are itemised below for clarity:

- There is a general trend of increasing failure load when moving from separation to internal failure modes.
- The strongest joints fail through delamination of the upper base skin laminate (UBD).
- Tensile failure of the core occurred in two out of the 54 specimens, it is probable that this is due either to flaw in the core (or even to an exceptionally strong laminate skin) in these specimens. It must be remembered that the Coremat core is of two layers bonded together.
- There is no clear correlation between joint strength and the skin delamination (UBD) and web fillet crack (UWC) failure modes. Why this is the case is not explored here, and would require further work to investigate load and failure paths.
- All of the joints in the weaker of the two groups seen in Fig. 6 fail via the separation modes, BS, UBLWS and LBUWS, the latter two of which do not occur anywhere else.
- However, for the medium strength joints there is no clean cut hierarchy of failure mode in terms of joint strength; there are also stronger joints failing due to base separation, and for the Peel-ply prepared specimens cleaned with a simple clean cloth, the base separation (BS) joints are slightly stronger than those failing due to fillet crack (UWC) and base skin delamination (UBD).
- Cleaning with solvents does not have marked effect on the fail mode (which is not to say that it does not influence joint strength) except for the Crestomer joints with no surface preparation where it changes the failure mode from an interface one (BS) to an internal one (UBD) with a corresponding increase in strength which is the largest single effect of all those seen in this study.

- It can be inferred that the large differences in interface strengths is due to differences in the bond strength in each case.
- However, it is seen that some delamination failure (UBD) joints are significantly weaker than others. It would perhaps be intuitive to think that the delamination strength of the base skin should be constant since this laminate is equal in all specimens. This phenomena could be because load paths have been changed by changes in some of the factor levels and hence skin delamination occurs at different loads; this would require further analyses of load paths, for example using FEA methods. Another possibility is that variations in the interlaminar tensile strength of the skin laminates may have limited the full effectiveness of some joints, since the first stage of vacuum assisted production is the difficult to control process of hand layup.

## 7. Conclusions

Statistical experimental design techniques have been used to study the multi-parameter problem of the bonding of composite materials through a large test program on 'T'-Joints representative of various joints used to fabricate marine composite structures. The effects of different surface preparation and cleaning methods and adhesives, along with the interactions between these effects, were investigated.

The open source software 'R' was extremely effective in statistically evaluating the effects of the various parameters on joint strength. The statistical linear model fitted the experimental data extremely well. Importantly, the statistical methods identified significant interaction effects; the effect of each parameter varied considerably between the different levels of the other parameters. This ability of statistically designed experimentation and analysis to systematically investigate, and to clearly represent graphically, factor interactions is a very powerful (if not essential) tool in any situation where multiple parameters affect the measured response and interactions between the factor effects are possible. Many areas of research into composite materials fall into this multi-parametric category.

Interaction plots were used to make engineering interpretations of the data:

Overall, the two best candidates for a strong joint are Crestomer with no surface preparation (failure load 1285 N) and Crystic with grinding (1187 N), both pre-cleaned with solvents. However, the combinations Peel-ply-Solvents-Crestomer, Grinding-Solvents-Crestomer and Grinding-Solvents-polyester putty (1049 N, 1030 N and 971 N, respectively) also give more than respectable joint strength, and the cheap cost and simplicity of the latter of the three could prove advantageous.

However, there are other practical production and cost considerations to be taken into account which may mean that the strongest joint is not necessarily the optimum one. Hence, the following additional conclusions were also made via inspection of the interaction plots

- Crestomer bonded joints should be cleaned before bonding using solvents.
- If Crystic is used then the surface *must* be prepared either by grinding or using peel-ply.
- If a Polyester putty is used, the surface *must* be prepared either by grinding or using peel-ply.



- If no surface preparation is preferred then neither Crystic nor polyester putty should be used.
- If the surface is prepared by grinding then all three adhesives give a strong bond, with solvents giving the most effective cleaning in each case.
- If peel ply is used then again all three adhesives give a strong bond, but the effect of cleaning before bonding with solvents is not so straightforward.
- There is a general trend of increasing failure load when moving from separation to internal failure modes; the strongest joints fail through delamination of the upper base skin laminate; the weakest joints fail via some form of clean separation of the adhesive from the substrate; however, for the medium strength joints there is no clear-cut correlation between failure mode and joint strength.
- Cleaning with solvents does not have marked effect on the failure mode, except for the Crestomer joints with no surface preparation where the change from an interface to an internal failure gives a corresponding increase in strength which is the largest single effect of all those seen in this study.
- It can be inferred that the large differences in interface strengths is due to differences in the bond strength in each case.
- It is not known why some delamination failure joints are significantly weaker than others; further work would be required to explain this.

## Acknowledgments

This work was performed within the Strategic Research Plan of the Centre for Marine Technology and Ocean Engineering, which is financed by Portuguese Foundation for Science and Technology (Fundação para a Ciência e Tecnologia-FCT). The specimens were designed by and fabricated under the supervision of Eng. Gil Pina Cabral whilst at ENP shipyards, Peniche, Portugal.

## References

1. Sheno A, Beck R, Boote D, Davies P, Hage A, Hudson D, Kageyama K, Keuning JA, Miller P, Sutherland LS. Committee V.8 - Sailing Yacht Design. In: Hong CD, Jang SY, editors. Proceedings of the 17th International Ship and Offshore Structures Congress (ISSC), Seoul, 16-21 August 2009. P. 433-493.
2. Roland F, Manzon L, Kujala P, Brede M, Weitzenböck JR. Advanced joining techniques in European shipbuilding. *Journal of Ship Production* 2004;20(3):200-210.
3. Wang X, Starlinger A, Koch S, Moggia A. Structural design of bonded joints with flexible adhesive for the superstructure of ship. NAV 2003, Naples, 2003.
4. Weitzenböck JR, McGeorge D. BONDSHIP: developing guidelines for adhesive bonding in shipbuilding. Rapperswil: SwissBonding, May 2005.
5. Cantrill J, Kapadia A, Pugh D. Lessons learnt from designing & producing adhesively bonded prototyping structures in a shipyard. *Proceedings of the Institution of Mechanical Engineers Part M: Journal of Engineering for the Maritime Environment* 2004;218(4):267-272.

6. Davies P, Choqueuse D, Bigourdan B, Gautier C, Joannic R, Parneix P, L'Hostis J. Design, manufacture & testing of stiffened panels for marine structures using adhesively bonded pultruded sections. *Proceedings of the Institution of Mechanical Engineers Part M: Journal of Engineering for the Maritime Environment* 2004;218(4):227-234.
7. Baur P, Roy A, Casari P, Choqueuse D, Davies P. Structural mechanical testing of a full-size adhesively bonded motorboat. *Proceedings of the Institution of Mechanical Engineers Part M: Journal of Engineering for the Maritime Environment* 2004;218(4):259-265.
8. Sutherland LS, Sheno RA, Lewis SM. Size and Scale Effects in Composites: II. Unidirectional Laminates. *Composites Science and Technology* 1998;59:221-233.
9. Sutherland LS, Sheno RA, Lewis SM. Size and Scale Effects in Composites: III. Woven-Roving Laminates. *Composites Science and Technology* 1998;59:235-251.
10. Sutherland LS, Guedes Soares C. The Effects of Test Parameters on the Impact Response of Glass Reinforced Plastic using an Experimental Design Approach. *Composites Science & Technology* 2003;63:1-18.
11. Grove DM, Davis PD. *Engineering Quality & Experimental Design*. New York: Longman, 1992.
12. Box GEP, Hunter WG, Hunter JS. *Statistics for Experimenters*. New York: Wiley, 1978.
13. Montgomery DC. *Design and analysis of experiments - 8th edition*. New York: Wiley, 2012.
14. R Core Team. *R: A language and environment for statistical computing*. Vienna: R Foundation for Statistical Computing, 2015.
15. RStudio Team. *RStudio: Integrated Development for R*. Boston, MA: RStudio Inc., 2015.
16. Levene H. Robust tests for equality of variances. In: Olkin I, Hotelling H, et al. editors. *Contributions to Probability and Statistics: Essays in Honor of Harold Hotelling*. Palo Alto, CA: Stanford University Press, 1960. p. 278–292.
17. Sutherland LS, Guedes Soares C. Investigating T-joint strength parameters using statistical experimental design and analysis techniques. In: Guedes Soares C, Santos TA, editors. *Maritime Technology and Engineering 3*. London: Taylor & Francis Group, 2016.